



广州科励特舞台设备有限公司
Guangzhou Coreat stage equipment CO.,LTD.

Electric hoist operation manual

型号 Type:KLT-8P



Guangzhou Coreat Stage Equipment Co., Ltd.

<https://globalcoreat.com> E-mail:info@globalcoreat.com Tell:+86 15920506425

1、简介 Brief introduction

1.1 Coreat系列环链电动葫芦控制器 KLT-8P 设计用于控制电动葫芦的操作，可与多台控制器联合控制。

1.1 The Coreat series chain electric hoist controller KLT-8P is designed to control the operation of chain electric hoists and can be jointly controlled with multiple controllers.

1.2 不适合在爆炸性环境中使用。

1.2 Not suitable for use in explosive environments.

2、设备的一般信息 General information of the equipment

2.1 Coreat系列环链电动葫芦的 KLT-8P控制器，提供对环链电动葫芦操作的控制。

2.2 该设备是按照技术规范的要求进行设计的。

通用用电设备配电设计规范(GB50055-93)

低压配电装置及线路设计规范(GB50054-95)

3、设备技术数据及特点

设备的技术数据和特性见表3.1。

NO.	范围Range	意义
1	控制通道数量，个 Control the quantities of channels, PC	8
2	每相最大功率，A Maximum power per phase,A	16
3	指示面板上设备输入端是否存在电压的LED，个 LEDs indicating whether there is voltage at the input terminal of the device on the panel, PC	1
4	三相断路器数量，个 Quantities of three-phase circuit breakers	1
5	面板上运动控制按钮的数量，个 The quantities of motion control buttons on the panel,PC	8
6	CEE-16/4连接器数量，个 CEE-16/4 Quantitys of connectors,PC	8
7	CEE-32/5连接器数量，个 CEE-32/5 Quantitys of connectors,PC	1
8	重量，公斤 Weight,kg	12
9	面板上的紧急关闭按钮 Emergency shutdown button on the panel	可用性 usability
10	面板上的START按钮 START button on the panel	可用性 usability
11	面板上的手动、连动切换旋钮 Manual and linkage switching knobs on the panel	可用性 usability
12	面板上的XLR3针母连接器 XLR3 pin female connector on the panel	可用性 usability
13	控制类型 Control type	直接的 Direct
14	外壳材质 Shell material	ABS
15	电源电压 Supply voltage	400V/3P+N+PE
16	每个输出都是独立的 Each output is independent	可用性 usability

4、操作说明 Operating instructions

4.1 控制 Control

控件和状态指示灯位于控制器前面板上和内部，控制面板外观如图 4.1 所示

The controls and status indicator lights are located on and inside the front panel of the controller, and the appearance of the control panel is shown in Figure 4.1



4.2 电动葫芦控制器操作步骤 Operation steps of electric hoist controller

- 1)、电动葫芦分别用延长电缆线接到葫芦输出端。
1). The electric hoist is connected to the output end of the hoist with extension cables.
- 2)、将手动、连接切换开关拨向 M 手动方向。
2). Turn the manual and connection switch to the M manual direction.
- 3)、打开电源总开关，查看电源指示灯是否正常。
3). Turn on the main power switch and check if the power indicator light is working properly.
- 4)、向右旋动急停开关“STOP”确定急停开关已经弹上来。
4). Rotate the emergency stop switch "STOP" to the right to confirm that the emergency stop switch has popped up.
- 5)、把对应要升或降的电动葫芦在换向开关处选择。
5). Select the corresponding electric hoist to be raised or lowered at the reversing switch.
- 6)、按启动按钮即可升降电动葫芦。
6). Press the start button to lift or lower the electric hoist.

在工作前必须点动检测，如果所有电动葫芦的上升和下降方向与控台上的标志不同，停电后将电源的相序调换即可（此操作必须由专业电工操作）。单个电动葫芦与其它的葫芦运行方向不一致就要调换单条线的相序，此操作在同步控制前必须检查好，确定所有葫芦的运行主向一致后才能可进行同步升降。

Before starting work, it is necessary to perform a jog detection. If the rising and falling directions of all electric hoists are different from the signs on the control panel, the phase sequence of the power supply

can be switched after a power outage (this operation must be carried out by a professional electrician). If the direction of operation of a single electric hoist is not consistent with that of other hoists, the phase sequence of a single line must be switched. This operation must be checked before synchronous control to ensure that the main direction of operation of all hoists is consistent before synchronous lifting can be carried out.

4.2 电路图 Circuit diagram

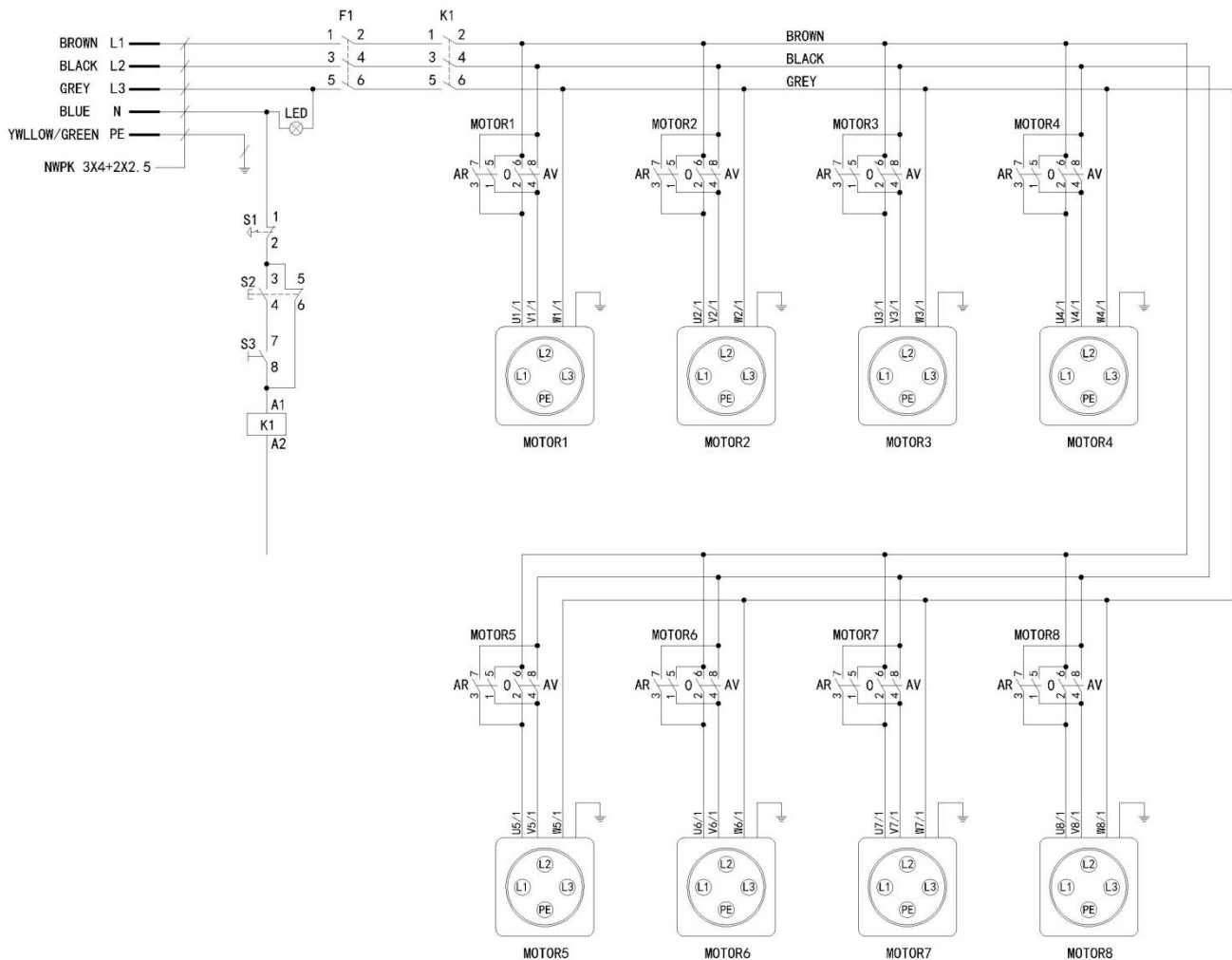

4.3 注意事项 Note

- 1)、控台在使用时要干燥并且淋不到雨的地方。
1). The control panel should be kept dry and not exposed to rain during use.
- 2)、进行升降操作时现场必须有一个指挥人员，观察设备在上升和下降过程中的运行情况，发现问题即时停止。
2). There must be a commander on site during the lifting operation to observe the operation of the equipment during the lifting and lowering process, and to stop immediately if any problems are found.
- 3)、停止运行后选择开关和运行开关要解除，防止误操作。
3). After stopping the operation, the selection switch and the operation switch should be released to prevent accidental operation.
- 4)、升降完毕后解除选择开关、关闭总开关、断开总电源。
4). After the lifting is completed, release the selection switch, turn off the main switch, and disconnect the main power supply.
- 5)、注意整机防水，防尘。
5). Pay attention to waterproof and dustproof of the whole machine.

5 Certificate of conformity

5、合格证

Electric hoist controller
电动葫芦控制器

Coreat KLT-8P

Factory No. 出厂编号

Fully compliant with regulatory requirements:
完全符合法规要求

TP TC 004/2011

关于低压设备的安全 Regarding the safety of low-voltage equipment

保修期为自销售之日起12个月。本保修不适用于因自然磨损、未遵守维修建议或安全规则、使用不当或人为造成的损坏，也不适用于未经允许私自改装的产品，未经特别许可私自进行维修。

The warranty period is 12 months from the date of sale. This warranty does not apply to damage caused by natural wear and tear, failure to follow repair recommendations or safety rules, improper use, or human error, nor does it apply to products that have been modified without permission or repaired without special permission.

Stamp 盖章

Technical Director
技术总监

(Date) (日期) 2024/08/20 (signature) (签名)